



DEN-ON INSTRUMENTS CO.,LTD



# RD-500 III

DIC is pleased to introduce to the electronic industry a new technologically advanced line.

**DIC REWORK SYSTEM**

# RD-500S III



# RD-500III • RD-500SIII

## BGA • SMT REWORK SYSTEM

### Trouble Free Control System



**New Controller**

No Hard Drive or Separate Computer Necessary.

### Features .....

- Trouble Free Internal Flash Memory Hard Drive
- 3 Separate Heaters for Lead Free Solder
- Long Wave IR Area Heater to Prevent PCB Warping
- 2 Mode Cooling Functions
- Security Lock-out Function
- 2 Point Component Control Auto-profiling
- Convenient Inspection Function
- 5 Thermocouple Inputs
- Fully Integrated from Solder Cream Application to Component Placement
- Semi-automatic System
- Useful for a Wide Variety of Rework



**RD-500III**

For Large Printed Circuit Boards  
(Maximum Size 500mm X 600mm)



**RD-500SIII**

For Standard Size Boards  
(Maximum 400mm X 420mm)



DIC is pleased to introduce to the electronic industry a new technologically advanced line.

## Stable and Safe Rework, Designed for Lead Free or Eutectic Solders, Large or Small Boards, Large or Small Components.



### ■ 3 Separate Heaters for Lead Free Rework

Because the top and bottom heaters are high power hot air, the machine is able to create and maintain an efficient reflow profile which is safe and stable. In addition, the system includes strong IR underside area heaters which prevent the PCB from warping.



### ■ 3 Point Cooling System

Once the reflow profile is complete, cool air is provide both through the nozzle and from a cooling fan which can be selected separately. The addition of cool air after the reflow cycle has been shown to improve lead free solder connections.

### ■ 2 Point Component Control Auto-profiling

The 2 Point Auto-Profile function allows the user to create an optimum profile automatically by monitoring the solder ball temperature for the solder reflow conditions and by monitoring the top of the component to ensure the component does not overheat during the profile.



**1** Take the thermocouples which have been attached to the top of the component and the solder ball and plug them into the Sensor Ports.

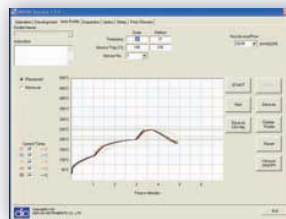

**2** In the Auto-Profile Tab, set the desired profile on the graph. During the test run, the Auto-Profile automatically measures and stores the data necessary for rework profile.



**3** Pull up the saved data in the Development Tab and run it again to confirm the profile.

## ■ Integrated Component Preparation, Alignment and Placement

The BP500 Solder Paste Preparation Kit is included as a standard accessory (stencils are optional). It allows the user to apply solder paste directly to the balls of the component. This is then placed in the Optic Arm and is ready for alignment to the PCB. The Alignment software then allows the user to zoom, focus, and split screen for maximum easy in alignment and placement. Here are the basic steps.

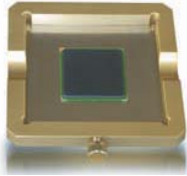

1 Place the component in the appropriate stencil.

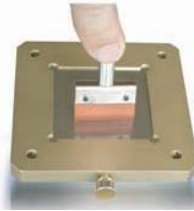

2 Apply solder or flux paste to the component.



3 Deploy the Optics Arm and place the BP500 with the component to be picked.

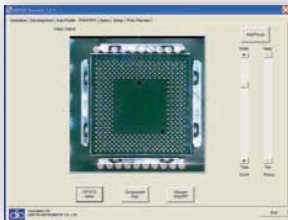

4 Using the table movement knobs, align the PCB to the component as necessary. If theta adjustment is required, it can be done via the Theta Adjustment Knob on the front of the heater head.

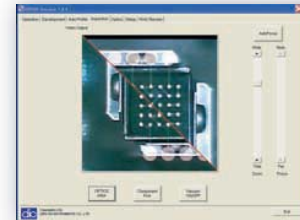
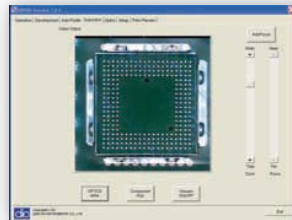

5 **Screen Split**  
The screen split function will enlarge and split the view so it is easier to view and align the component to the board.

## ■ Two Additional Confirmation Functions

### Inspection Function

In the Inspection Screen the user can input standardized profile data to compare to the saved profile data. The saved profile data will automatically be compared against the standardized data and the user will instantly see if the ramp rates and temperature zones are proper. There is a print out function which will eliminate the need for writing separate reports.



### Operation Screen Confirmation Capability

From the Operation Screen the user can also pull up a previous profile and overlay it against a current profile for easy comparison.

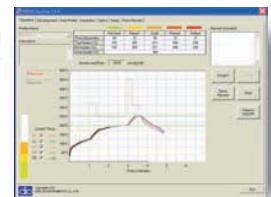

### Software Function



Operation	The Operation Tab is where the standard operator will access the profiles that have been developed by the engineer.
Development	The Development Tab is where profiles are developed or modified.
Auto-Profile	The Auto-Profile Tab is for automatically making a profile using 2 thermocouples. The top and bottom heaters will adjust for the best reflow conditions for the solder joint and component.
Inspection	In the Inspection Tab, the user can compare a reflow profile against pre-set ramp rate and temperature zone conditions.
Optics	The Optics Tab is where component will be automatically picked up and the user will manually align it to the board using the alignment screen.
Setup	The Setup Tab is where the basic functions of the machine are set. These include Security Password set up, Upper and Lower Indicator Lines, Standby Temperature for the Area Heater and the Gross Placement Force.
Print/Review	The Print/Review Tab allows the user to compare and overlay two profiles on the graph, write comments and then print them.

# Globally Recognized Rework System

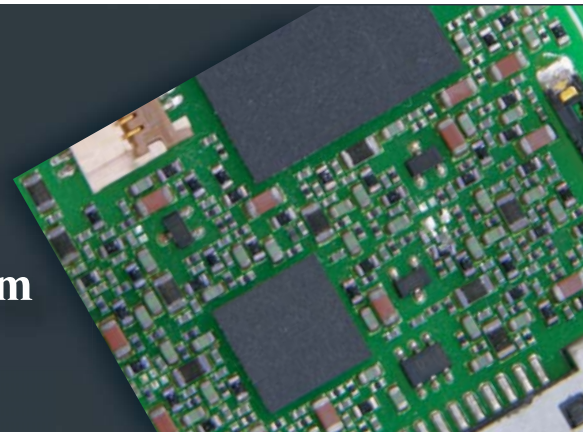

**RD-500III Overall Dimensions**

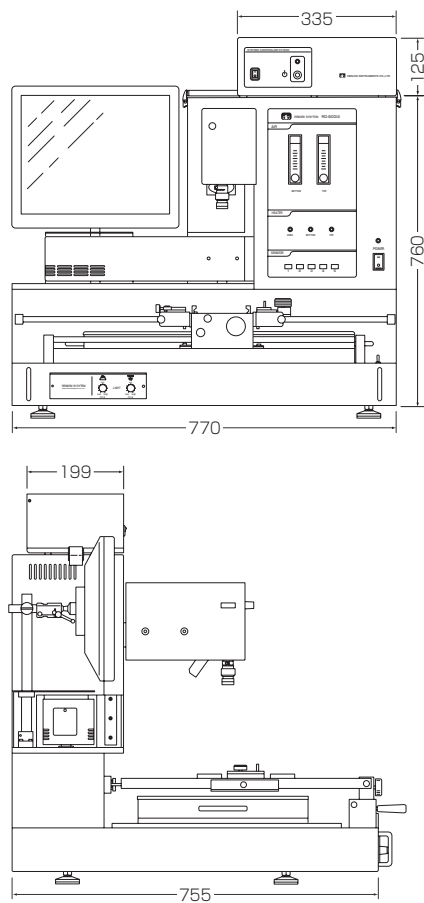

**RD-500SIII Overall Dimensions**

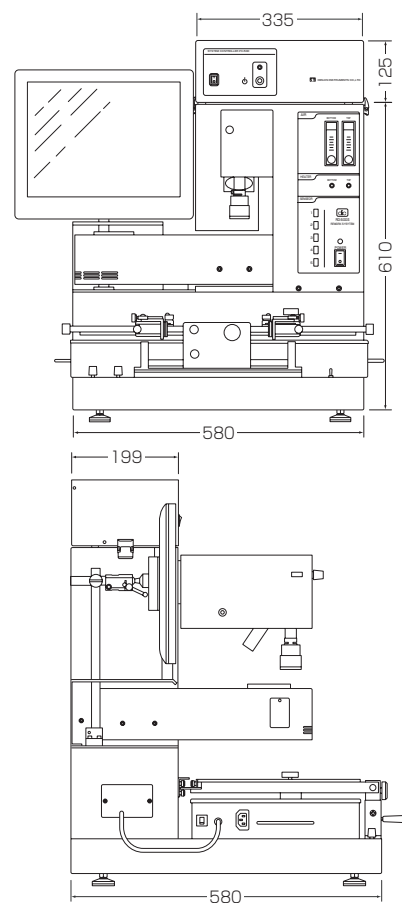

RD-500III	Specifications	RD-500SIII
500mm×600mm	Maximum PCB Size	400mm×420mm
2mm-50mm	Device Size Range	2mm-50mm
+/- 0.025mm	Placement Accuracy	+/- 0.025mm
700 Watt Hot Air	Top Hot Air Heater	700 Watt Hot Air
700 Watt Hot Air	Bottom Hot Air Heater	700 Watt Hot Air
400 W x 6 (IR) 2400 Watt Total	Area Heater	400 W x 3 (IR) 1200 Watt Total * Optional
0~650°C	Emperature Setting Range Top & Bottom Hot Air Heater	0~650°C
0~650°C	Temperature Setting Range Area Heater	0~650°C
Controller (PC-500)	PC Operating System	Controller (PC-500)
15 Inch LCD Display	Monitor Size	15 Inch LCD Display
770W x 755D x 885H (without foot)	Overall Size	580W x 580D x 735H (without foot)
Approx.78 kgs	Overall weight	Approx.50 kgs
80L/min 0.2-1.0Mpa	Air Requirement	80L/min 0.2-1.0Mpa
AC200-230V 3.8kw	Electrical Requirement	AC100-120V or AC200-230V 2.6 kw (1.4kw for Main Body, 1.2kw for Area Heater)

## ■ Safety Features

The RD-500III and the RD-500SIII share the same set of unique safety features that make operating the machine simple and safe. These include;

### Initialization Check

When the unit is initially powered up, the software will check all the major motion sensor and heating functions. If there is any problem such as an open heater sensor, the software will prevent the machine from operating until the problem is fixed and the error is cleared.

### Airflow Sensor

There is an airflow sensor that will prevent the machine from running if there is insufficient airflow into the machine.

### Heater Overload Sensor

Should either airflow heaters see a condition where there is full power for more than 60 seconds, the unit will automatically stop the cycle.

### Thermo-protector Cutoff Switch

The cutoff switches act as breakers in a condition where the heaters become overheated. If they reach a certain temperature they will cut off power to the heater.

### Heater Head Slip Clutch

When the heater head moves up or down, if there is an obstruction, the slip clutch will activate and prevent injury or damage to the board.

### Low Strength Optics Arm

The power that drives the Optics Arm is low so that any obstruction to the movement will cause it to stop deployment for safety.

## ■ Nozzles



Nozzle without Adjustable Walls for BNZ-07 to BNZ-15

Part #	Size in mm (Inside Dimension)
BNZ-07	7×7
BNZ-09	9×9
BNZ-13	13×13
BNZ-15	15×15



Nozzle with Adjustable Walls for BNZ-18 to BNZ-52

Part #	Size in mm (Inside Dimension)
BNZ-18	18×18
BNZ-20	20×20
BNZ-22	22×22
BNZ-24	24×24
BNZ-26	26×26
BNZ-28	28×28
BNZ-30	30×30
BNZ-32	32×32
BNZ-35	35×35
BNZ-37	37×37
BNZ-39	39×39
BNZ-44	44×44
BNZ-49	49×49
BNZ-52	52×52

## ■ Options



Odd size/shape PCB Holder

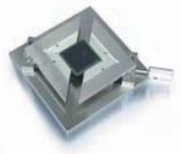

Multi Parts Holder



Board Support Bracket



RD500-SIII Area Heater

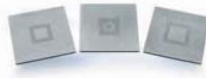

Stencils



Table with Drawer, Wheels and Adjustable Leveling Feet

## ■ Standard Accessories

- RD-500III & SIII Exclusive Controller/PC-500
- Flat Panel Display
- Board Support Bracket (Optional for RD-500SIII)
- Bottom Heater Nozzle, Big and Small 1 each
- Vacuum Pad, Small, Medium and Large 3 each
- K-Type Thermocouples 5 each
- BP-500 Solder Paste Preparation Kit
- Squeegee
- Board Stopper



Small Board Holder for Small Size PCB



EXPORTER  
**DIC TRADING CO.,LTD**  
 1-26-10 SEKIMACHI-HIGASHI, NERIMA, TOKYO 177-0052, JAPAN  
 TEL [81] 3-3929-6800 FAX [81] 3-3929-7441

**i-tronik**<sup>®</sup>  
 Macchine e prodotti per l'industria elettronica

**i-tronik S.p.A**  
**Via dell'Artigianato n. 20**  
**35010 Peraga di Vigonza (PD)**  
**Tel. +39.049.895.23 Fax. +39.049. 893.4822**  
**commerciale@itronik.it; www.itronik.it**

※ Specifications and prices are subject to change without notice. Specification Revision Date: May 2008.