

SMT 2017 BOARD CLEANER



An ITW Company



SMT 2017

BOARD CLEANER



An ITW Company

Teknek introduce the "Benchmark" in board cleaning with the SMT2017. World class contact cleaning is achieved within a static controlled environment developed specifically to meet international ESD standards. Increased board processing capability is another innovation in the design of this state of the art product.

SPECIFICATION

TWO CLEANING WIDTHS	40 - 400mm / 40 - 600mm
OPERATING MODES	Double Side - Bypass or Single Side - Bypass
ROLLER TYPES AVAILABLE	Nanocleen™ 20.20
ADHESIVE	ARLS - Low Static Adhesive
PROCESSING SPEED	1-40 m/mm
PASS LINE HEIGHT	900 ± 50mm
POWER SUPPLY	Universal Power supply
PNEUMATIC PRESSURE REQUIRED	5-7 bar oil free compressed air

ESD COMPLIANCE

MACHINE	ANSI / ESDs 20.20 - 2014
NONOCLEEN™ 20.20	ANSI / ESDs 6.1 - 2014

EQUIPMENT GROUNDING COMPLIANCE

ANNEX A (Automated Handling Equipment)

ALL TEKNEK ROLLERS COMPLIANCE

ISO 7123 Class A

ALL TEKNEK ADHESIVE ROLLS - COMPLIANCE

FINAT



SMT DATA

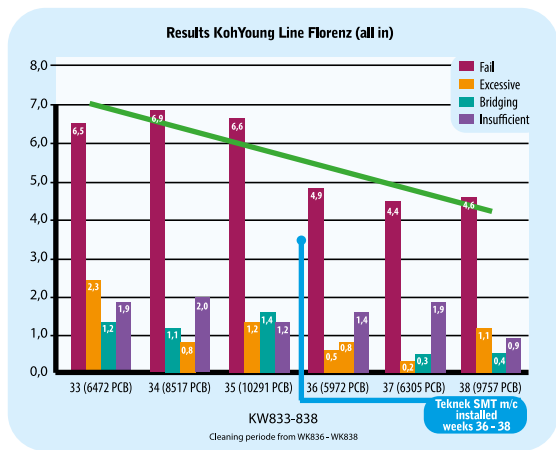
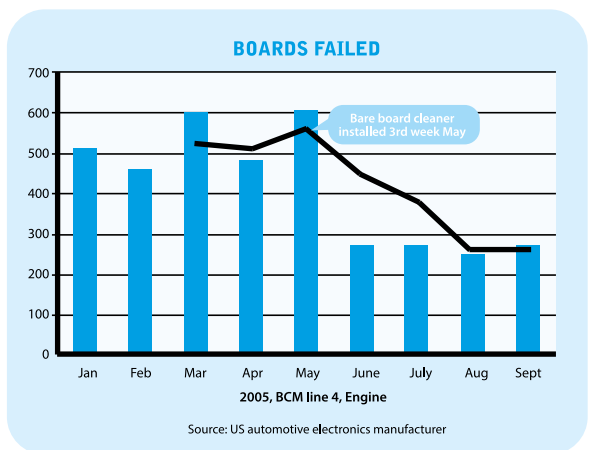

FEATURES

BENEFITS



Rollers & Adhesive



Low Static Environment



Nanoclean™ 20.20 + ARLS Low Static adhesive ensures the SMT2017 offers world class contact Cleaning. Traditional silicone based rollers are also available through the RFQ process.

All Rollers are manufactured to ISO 6123 Class A. All Adhesive Rolls are manufactured to FINAT standards.

The new SMT2017 was specifically designed to meet International standard for ESD. A low static Environment has been created through which the bare board is processed.

Static Management was the key innovation, which drove the development of the SMT2017.

Compliance:

ANSI / ESDs 20.20 - 2014 & ANSI / ESDs 6.1 - 2014



Static Management

Industry demands minimal static charge within the Surface Mount process, this is the drive behind the introduction of the AERO Bar from Simco. On exit of the SMT2017, ~35v on the surface of the board can be achieved using Nanoclean™ - ARLS Adhesive and the AERO Bar.

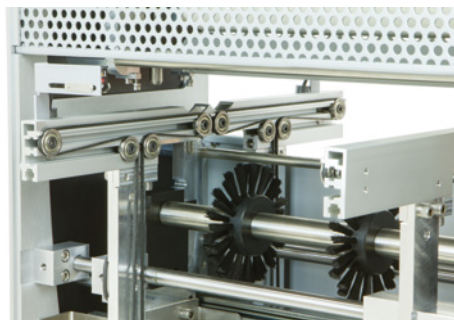

Increased Capability

The introduction of a continuous Rail system on the Single side SMT2017 increases board processing capabilities. Boards at 50x50mm - 600x600mm can be smoothly processed and cleaned through this machine.

The new rail design & light weight roller technology provide Low Applied Pressure to the surface of the board. NO damage to embedded circuits & components.



New Operator interface

Teknek has incorporated a new, faster PLC from ProFace. This easy to use, multi lingual touchscreen ensure minimal training is required to setup and operate the SMT2017.

The new software has the ability to store 250 different board programs making change over quick & easy.

SMT 2017

BOARD CLEANER



An ITW Company

TECHNICAL SPECIFICATION

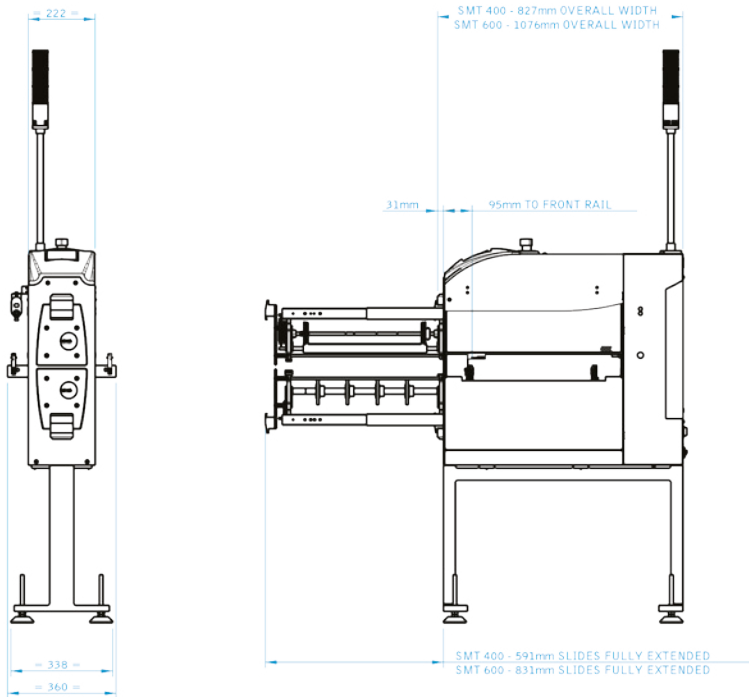

Note: Customer can fit ARLS 320 to the SMT2017

CAPABILITY

BOARD PROCESSING			
DOUBLE SIDE CLEANING	Min - Max Length	98mm - N/A	98mm - N/A
	Min - Max Width	40mm - 400mm	40mm - 600mm
	Min - Max Thickness	0.6mm - 3.2mm	0.6mm - 3.2mm
BY-PASS NO CLEANING	Min - Max Length	120mm - N/A	120mm - N/A
	Min - Max Width	40mm - 400mm	40mm - 600mm
	Min - Max Thickness	0.6mm - 3.2mm	0.6mm - 3.2mm
SINGLE SIDE CLEANING	Min - Max Length	50mm - N/A	50mm - N/A
	Min - Max Width	40mm - 400mm	40mm - 600mm
	Min - Max Thickness	0.6mm - 3.2mm	0.6mm - 3.2mm
BY-PASS NO CLEANING	Min - Max Length	50mm - N/A	50mm - N/A
	Min - Max Width	40mm - 400mm	40mm - 600mm
	Min - Max Thickness	0.6mm - 3.2mm	0.6mm - 3.2mm

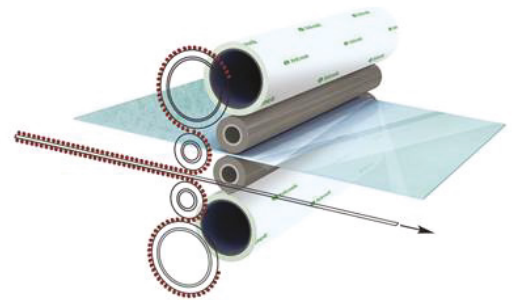

WORLD LEADER IN CONTACT CLEANING

Teknek Head Office
River Drive
Inchinnan Business Park
Renfrewshire, PA4 9RT
Scotland, UK

T: +44 (0)141 568 8100
F: +44 (0)141 568 8101

Teknek Japan Ltd
1-2-4, Minatojima-Nakamachi,
Chuo-ku,
Kobe 650-0046
Japan

T: + 81 (0)78 304 5780
F: +81 (0)78 304 5781

Teknek China Ltd
Unit E, 4/F,
Winfield Industrial Building,
3 Kin Kwan Street,
Tuen Mun, N.T.
Hong Kong

T: +852 2468 3160
F: +852 2462 3036

Teknek (Simco-Ion)
2257 North Penn Road
Hatfield,
PA 19440
USA

T: +1 215 822 6401
E: ussales@teknek.com

